

# INSTRUCTION MANUAL

# SERVO-MATCH CONTROL MANUAL

PERKIN-ELMER  
ULTEK INC.

# INSTRUCTION MANUAL

## SERVO-MATCH CONTROL MANUAL

## TABLE OF CONTENTS

SECTION 1 – GENERAL DESCRIPTION .....	1-1
MODES OF OPERATION .....	1-1
Manual .....	1-1
Automatic .....	1-1
SPECIFICATIONS .....	1-1
SHIPPING WEIGHT .....	1-1
FILAMENT IGNITER .....	1-1
SECTION 2 – INSTALLATION .....	2-1
RECEIVING AND UNPACKING .....	2-1
INSTALLATION – RANDEX 2400 SERIES SYSTEM .....	2-1
INSTALLATION – RANDEX 3400 SERIES SYSTEM .....	2-2
CHECK-OUT PROCEDURE .....	2-3
SECTION 3 – OPERATION .....	3-1
THEORY OF OPERATION .....	3-1
SECTION 4 – TROUBLESHOOTING .....	4-1
SECTION 5 – PARTS LIST .....	5-1
SECTION 6 – REPLACEMENT PARTS .....	6-1
SECTION 7 – DRAWINGS .....	7-1

## SECTION 1 GENERAL INFORMATION

The Servo-Match Control is designed to provide automatic matching network setting for minimum VSWR.

The Servo-Match Control is capable of precisely controlling the matching network impedance to maintain the VSWR at 1.4 or below.

All operator controls are located on the front panel and all electrical connections are made at the rear panel. A single P.C. board contains the entire electronic circuitry. All power logic and control signals are obtained through the control cable. The sensor box measures the phase relationship in the R.F. cable.

### MODES OF OPERATION

#### Manual

In the manual mode of operation sputterhead matching impedance can be changed by means of TUNE and LOAD switches located on the sputterhead or meter control chassis.

#### Automatic

In the automatic mode of operation the sputterhead network will match R.F. generator output automatically.

### SPECIFICATIONS

Panel: 19" (493 mm) wide X 3½" (89 mm) high X 16" (406 mm) deep.

### SHIPPING WEIGHT

15 lbs (6.8 kg)

(Usually shipped, installed in a system).

### FILAMENT IGNITER (Part of Sputtering Head Assembly)

The igniter circuit ionizes the plasma by turning on a filament located inside the chamber. This filament of thoriated tungsten wire has a potential of 6V RMS across it and is biased with 400V RMS. The filament, with power applied, looks similar to an incandescent lamp. When turned on, electrons emitted during the negative portion of the cycle ionize the gas and, thus, ignite the plasma. When ignition takes place a negative target bias voltage is developed. A portion of this voltage is used through a metering circuit to turn the igniter off. When the igniter is off a 1 level logic signal is supplied to the Servo-Match chassis through J8 pin U. The igniter control circuit output can also be wired to supply a 1 level logic signal to the Servo-Match before ignition, when the filament is "ON".

Reference:

Filament Igniter Schematic  
Filament Igniter Schematic

C721-300-000  
C221-042-000

## SECTION 2 INSTALLATION

### RECEIVING AND UNPACKING

The unit is usually shipped installed in the system with the control cable(s) and RF cable to the matching network connected. If the unit is shipped as a replacement or spare, a special packing case is provided. In unpacking, avoid marring the painted surface or otherwise damaging the unit. All items of shipment should be inspected for evidence of damage. If damage is found, a claim should be filed with the carrier and a copy forwarded to Perkin-Elmer Ultek. If the equipment is to be returned for inspection or repair, authorization must be obtained from Perkin-Elmer Ultek prior to return, and instruction will be forwarded.

### INSTALLATION – RANDEX 2400 SERIES SYSTEMS

Installation consists of mounting the Servo-Match chassis in a rack or setting it on a level surface. Control and RF cables are connected as indicated in the chart below. Because of the design of the chassis, no attempt should be made to shorten or otherwise alter any cable associated with the Servo-Match Control.

#### WARNING

The RF power supply main circuit breaker must be off when making any cable connections or when any cable is removed or disconnected.

TABLE 1  
RANDEX 2400 SYSTEM SERVO-MATCH CONTROL

MODEL	CHASSIS PART NO.	CONTROL CABLE PART NO.	RF OUT CABLE PART NO.	RF IN CABLE PART NO.
2kW Standard	221-173-600	721-023-000	721-059-000	721-058-000
Horizontal Power Splitting	221-173-700	721-023-000	721-059-000	721-058-000
Etch	221-173-800	721-023-000	721-059-000	721-058-000

The control cable used with Randex 2400 systems is a grey 8-½-foot shielded cable with 19-pin MS connectors on each end. It connects the Servo-Match chassis (P8) to the sputtering head (J8). This cable supplies all necessary signals to the sputtering head for automatic tuning and is also the source for AC power which is required to operate the Servo-Match Control.

The RF output cable is a 6-foot-long RG8A/U coaxial cable with "N"-type connectors. This cable supplies the RF power to the sputtering head. It connects between the RF connector marked RF OUT on the rear of the Servo-Match Control and the RF input on the sputtering system.

The RF input cable is a 10-foot-long (or longer) RG8A/U coaxial cable with "N"-type connectors. This cable connects from the RF generator output to the connector marked RF IN on the rear of the Servo-Match Control.

**NOTE**

Servo-Match Control chassis part no. D221-173-600, D221-173-700 and D221-173-800 are supplied with a control cable and 6-foot RF coaxial cable as part of the Servo-Match Control. When returning these units for service, repair or exchange be sure to include the cables. On all other Servo-Match chassis the cables are part of the sputtering system and should be identified separately if returned.

**INSTALLATION – RANDEX 3400 SERIES SYSTEMS**

**TABLE 2  
3400 SYSTEM SERVO-MATCH CONTROL**

MODEL	CHASSIS PART NO.	CONTROL CABLE #1 PART NO.	CONTROL CABLE #2 PART NO.	RF OUT CABLE PART NO.	RF IN CABLE PART NO.
<b>5kW</b>					
Standard	221-136-100	721-023-000	220-943-900	221-084-600	221-084-500
Horizontal	221-118-200	721-023-000	220-943-900	221-084-600	221-084-500
Power Split					
Etch	221-078-600	721-023-000	none	221-084-600	221-084-500
<b>3kW</b>					
Standard	221-136-000	721-023-000	220-943-900	138-517-000	138-516-000
Horizontal	221-135-700	721-023-000	220-943-900	138-517-000	138-516-000
Power Split					
Etch	221-145-400	721-023-000	none	138-517-000	138-516-000

Two control cables are used with the 3400 system<sup>1</sup> Servo-Match Control. These cables, together with the two RF cables are part of the 3400 system interconnect and are not supplied with the Servo-Match Control. Cable 721-023-000 is a shielded control cable with 19-pin MS connectors. One end is connected to the rear of the Servo-Match connector (P8) and the other end to the lower right rear of the sputtering RF deck (J17). Cable 220-943-900 is a shielded control cable with 10-pin MS connectors. It connects from the rear of the Servo-Match Control (P41) to the lower right rear of the sputtering RF deck (J42). The RF 6-foot coaxial cable is connected from the Servo-Match

<sup>1</sup> see page 3-1, ETCH models

sensor marked RF OUT to the sputtering matching network. The second RF cable connects from the RF generator output to the rear of the Servo-Match Control RF IN. This cable is 10 feet or longer.

The RF cables differ with size and coaxial connections depending on the maximum RF power available. The following chart identifies connector assignments.

**TABLE 3  
RF CABLE AND COAXIAL CONNECTOR ASSIGNMENTS**

MAXIMUM RF POWER	CABLE TYPE	COAXIAL CONNECTIONS
0-2 kW	RG-8/U	"N"
0-3 kW	RG-14A/U	"HN"
0-5 kW	RG-17A/U	"LC"

**NOTE**

When connecting the RG-14A/U cable to the Servo-Match sensor box, right-angle HN adapters (part no. 178-151-700) are used to eliminate tight cable bends. These adapters are included with the Servo-Match chassis.

**CHECK-OUT PROCEDURE**

The Servo-Match Control is aligned before shipment and checked during installation. Under normal circumstances, the unit should not require readjustment. Before initial turn on, the cables should be secure and the MODE switch set to MANUAL. After establishing the proper argon pressure in the chamber, RF power can be applied (set at a low level). A plasma discharge should be observed and reading on the FORWARD POWER, BIAS voltage and, possibly, the REFLECTED POWER meters. The system must be matched manually first (by the means of LOAD and TUNE switches) to minimize reflected power reading. If low enough reflected power has been reached, then slowly increase the power to full while keeping reflected power reading low (reflected power should be 3% of forward power), decrease the RF power and switch into the AUTO mode. Adjust the LOAD ADJUST potentiometer to minimize reflected power. Adjustment should be in increments (10 to 20 degrees) one or the other direction while waiting 3 to 5 seconds between each increment. The LOAD control must be readjusted if the target material is changed and, in the BIAS mode if table spacing, pressure or power are changed.

If the Servo-Match control does not function properly, read the Theory of Operation, Section 3.

If any doubt about the Servo-Match exists, contact the Perkin-Elmer Ultek factory or local service group before attempting any alignment or servicing.

## THEORY OF OPERATION

The Servo-Match Control consists of two functional parts:

**Load Adjust Circuitry** — provides the amplitude ratio adjustment and operates semi-automatically. The level has to be readjusted whenever there is the need, e.g., change of target material. However, once set for the target and process, it will automatically readjust for that level whenever the target is selected. The small servo-loop consists of an error-detecting sensor (a rheostat coupled mechanically with the link). On the front panel are located potentiometers for load adjust presetting. The controller, with two output relays (K101 and K102) drives the link servo-motor. Load controller sensitivity can be changed (adjusted) by means of potentiometer, R50, located in the Servo-Match chassis on the PC board.

**Tune Circuitry** — provides the phase ratio adjustment and operates automatically. The servo-loop consists of an RF sensor, phase detector, analog/logic convertor, logic circuitry and two outputs. This signal drives the tuning capacitor servomotor. The RF sensor is located on the rear panel and has two RF connectors labeled POWER IN and POWER OUT and a variable capacitor (C14) for adjusting the reference voltage phasing. (See Servo-Match adjusting procedure, drawing number B221-166-50).

The phase detector is factory-aligned. Realignment is necessary if defective parts are replaced in this circuit. (See Servo-Match adjusting procedure drawing, number B221-166-50).

Sensitivity of the tune circuitry in the analog/logic converter is determined by the DC level at the junction of resistors R23, R21, R18, and R17.

**Etch Models** — (5kW, 3kW, 2kW) have only tune circuitry. Load adjustment is provided through the LOAD position switch located on the sputtering head (2400 series) or meter control chassis (3400 series).

**SECTION 4  
TROUBLESHOOTING**

**NOTES**

The Servo-Match control chassis will only function properly if the sputtering system tunes manually. If a stable plasma is not obtainable in the manual mode it is suggested that this problem be corrected first.

With the exception of RF power from the generator going through the Servo-Match sensor box and the tune control AC power, no other signals are required for manual operation.

**TROUBLE SHOOTING CHART**

SYMPTOM	PROBLEM	REMEDY
LOAD and TUNE switches are inoperative in both modes.	No 117 Vac control voltage in Servo-Match chassis.	Generator must be on; Load Lock must also be on (if equipped).
		Check for blown fuse outside the Servo-Match control.
		Check for loose, damaged or defective control cable.
LOAD switch will not drive the link in manual mode.	Relays K101 or K102 are not secure in their respective sockets.	Check security of relays K101 and K102.
	Relays K101 or K102 will not energize.	Check for defective relays.
		Q3, Q4, or Q5 is defective.
Link oscillates in the automatic mode.	Operational amplifier, U7, is defective.	
	Wiper contact on the potentiometer which is connected to the link drive motor is dirty (located in sputtering head).	Clean or replace.
	R50, 1K potentiometer set incorrectly.	Increase resistance.
Link will only drive in one direction.	Q3 defective	Replace Q3. Adjust R50 if necessary.
	Relays K101 and K102 are energized at the same time.	Check associated circuitry – replace defective component(s).
Link sets properly in the manual mode, but in automatic mode, will drive to its limit or drive in one direction only.	Check for proper automatic operation in another process.	Check signal(s) at J8 or J41 in the specific mode of malfunction.
		Check relays K105 through K108.
	Check potentiometers R56 through R60 and R64 through R66.	
	Part of the link servo-loop electronics is open or shorted.	Defective components – replace as necessary.

SYMPTOM	PROBLEM	REMEDY
Link will coast to a stop. Will not retune to the same position when set.	Clutch not engaging on link motor.	Trace signal from clutch to Servo-Match chassis. If proper signal (115 Vac) is observed, check for defective clutch on motor.
	Set-screws loose on link drive shaft.	Tighten set screws.
Link is not sensitive to small changes in position.	Potentiometer R50 out of adjustment.	Adjust R50 to a lower resistance.
In automatic mode, link adjusts properly but tune motor has a loud hum or vibration.	Triac CR12 and CR10 are both on.	Check for defective triac(s). Check associated circuitry of each triac for component failure — replace as necessary.
Link adjusts properly but tune motor will not adjust in automatic mode.	No zero signal at test point (output of U1) when system is in tune.	U1 defective.
		Defective component(s) in phase detector.
		See Servo-Match adjusting procedure, drawing B 221-166-500.
	Signal at test point is either + or - and can be changed with the tune switch.	Check outputs of U3 and U4. Check Logic levels of U5, and U6: i.e.: Load is adjusted. System in Auto Mode. Plasma is ignited.
In the automatic mode, reflected power indicates a higher level than if tuned in the manual mode.	Servo-Match out of alignment	Refer to Servo-Match adjustment procedure, drawing B 221-166-500.
In the automatic mode, reflected power will not always tune to the same level using the same target and mode.		
In the automatic mode, reflected power increases to maximum tuning stops.		
Unable to align Servo-Match using procedure as outlined in drawing B 221-166-500.	RF in and RF out cables reversed on sensor box.	Reverse cables, repeat alignment procedure.
	RF output cable too long or short.	Replace cable with correct length: 6'1" ± 1/4" for 2kW and 5kW. 6'1-3/8" ± 1/4" for 3kW. Repeat alignment procedure.

SECTION 5  
PARTS LIST

HOT FILAMENT IGNITER  
(REFERENCE SCHEMATIC C721-300-000)

DRAWING NO.	DESCRIPTION	PART NO.
C3, C4	Capacitor, 1000 mfd @ 25V	133-272-600
C14	Capacitor, .05 mfd @ 600V	133-272-000
C15, C18	Capacitor, 10 mfd @ 50V	133-273-400
All Other Capacitors	Capacitor, .01 mfd @ 1K	133-271-900
CR1, CR2, CR3, CR4, CR11, CR12, CR13	Diode, 1N4003	136-160-500
CR5, CR6	Diode, 1N4744A	136-161-200
CR7	Diode, 1N4749	136-160-900
CR8, CR9	Diode, 1N914	136-143-000
CR10	Diode, 1N4746	136-160-800
Q1	Transistor, 2N4221	136-637-000
Q2	Transistor, MU4891	136-637-710
Q3	Triac, 40796	136-300-400
R1, R2	Resistor, 470 $\Omega$ , 1W	134-132-600
R3	Resistor, 470K, $\frac{1}{2}$ W	134-283-000
R4, R9	Resistor, 10K, $\frac{1}{2}$ W	134-365-000
R5	Resistor, 4.7K, $\frac{1}{2}$ W	134-229-000
R6, R10	Resistor, 18K, $\frac{1}{2}$ W	134-370-000
R7	Resistor, 10K, 2W	134-082-900
R8	Resistor, 1K, $\frac{1}{2}$ W	134-340-000
R11	Resistor, 100 $\Omega$ , 1W	134-132-700
R12	Resistor, 270 $\Omega$ , $\frac{1}{2}$ W	134-454-800
R13	Resistor, 47 $\Omega$ , $\frac{1}{2}$ W	134-303-000
R14, R18	Resistor, 100K, $\frac{1}{2}$ W	134-403-000
R15	Resistor, 47K, $\frac{1}{2}$ W	134-372-000
R16	Resistor, 150K, $\frac{1}{2}$ W	134-237-000
R17	Varistor, V130LA1	134-940-200
T1	Transformer, PC110-40	132-082-800
T2	Transformer, 11Z2003	132-082-900
U1	IC, uL 747	136-708-100
XU1	IC, Socket D1P-14	121-952-600
	Complete Printed Circuit Board Assembly	721-567-000
	Printed Circuit Board Socket	139-927-000
	Filament Transformer	721-369-000
	Filament, Package of 10 filaments	721-625-000

**HOT FILAMENT IGNITER  
(REFERENCE SCHEMATIC G221-042-000)**

DRAWING NO.	DESCRIPTION	PART NO.
C1, C2	Capacitor, 39 pf	178-153-600
C5, C7	Capacitor, 10 mfd @25V	133-050-000
C12	Capacitor, .05 mf @ 600V	133-271-600
C16	Capacitor, 1000 mfd @ 50V	133-273-600
All Other Capacitors	Capacitor, .01 mf @ 1kV	133-271-900
CR1, CR6	Diode, 1N914	136-143-000
CR2, CR3	Diode, 1N4003	136-160-500
CR4	Diode, 1N4744	136-161-200
CR5	Diode, 1N4746	136-160-800
L1, L2, L3, L4	Choke, 3.3 uH	133-205-100
Q1	Triac, 40796	136-300-400
Q2	Transistor, 2N4891	136-637-710
R1	Resistor, 470K, ½W	134-283-000
R2	Resistor, 100K, ½W	134-403-000
R3	Resistor, 470 Ω, ½W	134-132-600
R4	Resistor, 47 Ω, ½W	134-303-000
R5	Resistor, 10K, 2W	134-082-900
R6	Resistor, 18K, ½W	134-370-000
R8	Resistor, 100K, ½W	134-132-700
R9	Resistor, 10K, ½W	134-365-000
R10	Varistor, V130LA1	134-940-200
R11, R12	Resistor, 15K, ½W	121-997-100
T1	Transformer, PC40-110	132-082-800
T2	Transformer, 11Z2003	132-082-900
U1	IC, MC 14011	136-707-900
XU1	IC, Socket,	140-226-000
	Complete Printed Circuit Board Assembly	221-016-400
	Printed Circuit Board Socket	721-567-000
	Filament Transformer	721-369-000
	Filament, Package of 10 filaments	721-625-000

**SECTION 6  
REPLACEMENT PARTS**

DRAWING NO.	DESCRIPTION	PART NO.
A1	Power Supply	122-047-700
C4, C5, C33, C37	Capacitor, .05 mf	133-271-700
C20, C25, C52, C55	Capacitor, 10 mfd @ 25V	133-050-000
C50, C51	Capacitor, 25 mfd @ 25V	133-273-900
C48	Capacitor, 250 mfd @ 25V	133-273-800
All Other Capacitors	Capacitor, .01 mf	133-271-900
CR1, CR2, CR3, CR4	Diode, matched set	721-426-000
CR5, CR6	Diode, 1N4744A	136-161-200
CR7, CR8, CR13, CR14, CR15, CR16, CR17, CR18	Diode, 1N4003	136-160-500
CR9, CR11	Diode, 1N914	136-143-000
CR10, CR12	Triac, 40796 or T4111M	136-300-400
K101, K102	Relay, 70RE2S-1000	135-922-000
K103	Relay, 78RE1-120VAC	135-921-900
K104	Relay, R10-E1-X4	135-928-200
K105, K106, K107, K108	Relay, KNP 5A21	135-928-300
L1, L2	Choke, 3.3uh	132-205-100
Q1, Q2	Transistor, MU4891	136-637-710
Q3, Q4, Q5	Transistor, 2N3393	136-636-000
R1, R3, R4	Resistor, 51 $\Omega$ , 3W	121-960-060
R2, R5, R6	Resistor, 10K matched set	721-424-000
R7, R8, R9, R16, R24, R26, R31, R35, R37, R46	Resistor, 1K, 1/2W	134-340-000
R10	Resistor, 2.2K, 1/2W	134-401-000
R13	Resistor, 5K, 5W	134-081-300
R14, R15	Varistor, V130LA1	134-940-200
R17, R21	Resistor, 560 $\Omega$ , 1/2W	134-733-000
R18, R23	Resistor, 15K, 1/2W	121-997-100
R19, R20	Resistor, 47 $\Omega$ , 1/2W	134-303-000
R27, R33, R44	Resistor, 47K, 1/2W	134-372-000
R28, R29, R32, R34, R36, R42, R43, R63	Resistor, 10K, 1/2W	134-365-000
R30, R54	Resistor, 100K, 1/2W	134-403-000

DRAWING NO.	DESCRIPTION	PART NO.
R38, R40	Resistor, 270 $\Omega$ , 1/2W	138-454-800
R39, R41	Resistor, 18K, 1/2W	134-370-000
R45	Resistor, 1K, 1W	134-132-900
R47	Resistor, 68K, 1/2W	134-374-100
R48	Resistor, 5.6K, 1/2W	134-407-000
R49, R51, R52	Resistor, 3.3K, 1/2W	134-355-000
R50	Potentiometer, 1K	134-136-400
R56, R57, R58, R59		
R60, R64, R65, R66	Potentiometer, 1K	134-571-400
R61, R62	Resistor, 10K, 2W	134-082-900
R70	Potentiometer, 1K	122-005-700
SW1	Switch with bezel	135-444-000
T1, T2	Transformer, 11Z2003	132-082-900
T3	Transformer, PC34-125	132-083-000
U1, U3, U4, U7	IC, uL 741	136-708-100
U5	IC, uL 14012	136-708-000
U6	IC, uL 14011	137-707-900
XDS1, XDSZ	Socket, lamp	122-030-300
XK101, XK102	Socket, relay	140-246-100
XK104	Socket, relay	122-046-600
XK105, XK106, XK107, XK108	Socket, relay	135-925-600
XU1, XU3, XU4, XU5, XU6, XU7	Socket, IC	121-952-600

#### PARTS COMMON TO 2kW SERVO-MATCH

Sensor assembly, complete		720-368-000
	Choke	122-029-400
Replacement	Capacitor	122-029-500
parts in	Connector UG22B/U	721-427-000
sensor assembly	Connector UG58A/U	140-177-000
	Toroid	721-420-000
RF cable from Servo-Match to sputtering matching network		720-105-900
RF cable from RF generator to Servo-Match (standard 10 Ft)		720-162-000
Control cable from J8 of Servo-Match to sputtering system		721-023-000

**PARTS COMMON TO 3kW SERVO-MATCH**

Sensor assembly complete		220-992-800
	Choke	122-029-400
	Capacitor	122-029-500
Replacement parts in sensor assembly	Connector UG560/U	140-251-000
	Connector UG61E/U	140-308-000
	Toroid	721-420-000
	Toroid assembly	721-421-000
Right-angle HN UG212A/U		178-151-700
RF cable from Servo-Match to sputtering matching network		138-517-000
RF cable from RF generator to Servo-Match (standard 10 Ft)		138-516-000
Control cable from J8 of Servo-Match to sputtering system		721-023-000
Control cable from J41 of Servo-Match to sputtering system		220-943-900

**PARTS COMMON TO 5kW SERVO-MATCH**

Sensor assembly complete		221-074-900
Replacement parts in sensor assembly	Toroid	122-030-100
	Capacitor, variable	122-029-500
	Choke	122-029-400
	Connector LC-UG352	211-130-800
Lamp		179-743-000
RF cable from Servo-Match to sputtering matching network		221-084-600
RF cable from RF generator to Servo-Match (standard 10 Ft)		221-084-500
Control cable from J8 of Servo-Match to sputtering system		721-023-000
Control cable from J41 of Servo-Match to sputtering system		220-943-900

SECTION 7  
DRAWINGS

SERVO-MATCH MASTER DRAWING CHART

SERVO-MATCH	FINAL ASSY	SCHEMATIC	P.C.B. ASSY	CHASSIS	P.C.B. FAB	P.C.B. SILKSCREEN	FRONT PANEL FAB.	FRONT PANEL SILKSCREEN	SENSOR	ALIGNMENT PROCEDURE
5kW - R	D221-136-100	D221-119-300	D221-132-700	D221-145-100	D221-108-200	B221-108-300	D220-935-600	C220-935-700	C221-074-900	B221-166-50
5kW - S	D221-118-200	D221-119-300	D221-132-700	D221-145-100	D221-108-200	B221-108-300	D220-935-600	C221-117-900	C221-074-900	B221-166-50
5kW - ETCH	D221-078-600	D221-120-700	D221-132-000	D221-146-300	D221-108-200	B221-108-300	D221-081-400	C221-081-500	C221-074-900	B221-166-50
3kW - R	D221-136-000	D221-119-300	D221-132-700	D221-145-100	D221-108-200	B221-108-300	D220-935-600	C220-935-700	C220-992-800	B221-166-50
3kW - S	D221-135-700	D221-119-300	D221-132-700	D221-145-100	D221-108-200	B221-108-300	D220-935-600	C221-117-900	C220-992-800	B221-166-50
3kW - ETCH	D221-146-400	D221-120-700	D221-132-000	D221-145-300	D221-108-200	B221-108-300	D221-081-400	C221-081-500	C220-992-800	B221-166-50
2kW - STD	D221-173-600	D221-173-300	D221-173-400	D221-173-500	D221-108-200	B221-108-300	D720-603-000	C720-638-000	C720-368-000	B221-166-50
2kW - HPS	D221-173-700	D221-173-300	D221-173-400	D221-173-500	D221-108-200	B221-108-300	D721-649-000	C721-648-000	C720-368-000	B221-166-50
2kW - ETCH	D221-173-800	D221-120-700	D221-132-000	D221-145-300	D221-108-200	B221-108-300	D221-081-400	C221-081-500	C720-368-000	B221-166-50



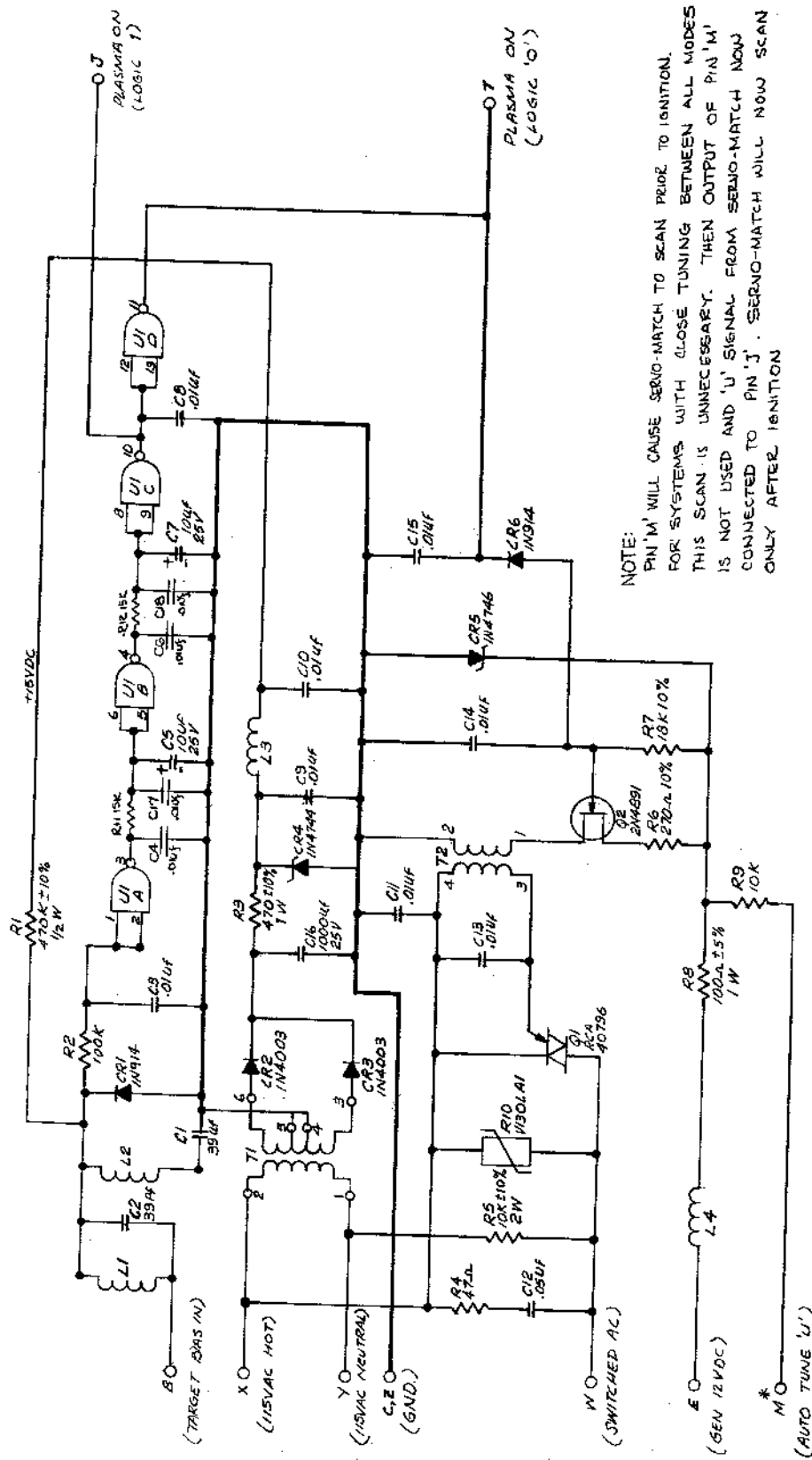

NOTE:  
 PIN 'M' WILL CAUSE SERVO-MATCH TO SCAN PRIOR TO IGNITION.  
 FOR SYSTEMS WITH CLOSE TUNING BETWEEN ALL MODES  
 THIS SCAN IS UNNECESSARY. THEN OUTPUT OF PIN 'M'  
 IS NOT USED AND 'U' SIGNAL FROM SERVO-MATCH NOW  
 CONNECTED TO PIN 'J'. SERVO-MATCH WILL NOW SCAN  
 ONLY AFTER IGNITION

MHTL IGNITER SCHEMATIC (C-221-042-000)

- NOTES:
3. U1 IS MC1401CL, +15V PIN 14, GND, PIN 7
  2. ALL L'S ARE 3.9 UH
  1. ALL RESISTOR VALUES ARE IN OHMS AND ARE 1/2 W, ±5% UNLESS OTHERWISE SPECIFIED.

**SERVO MATCH ADJUSTING PROCEDURE**  
**PHASE DETECTOR BALANCE ADJUSTMENT** (SCHEMATIC D221-113-300, D221-113-300,  
 D221-120-700 OR OLD  
 VERSION D221-163-200)

- a. Connect clip lead from intersection R13 (5K) and R4(51 ohms) to external test point.
- b. Switch into manual mode and turn on RF power to about 1/3 full power.
- c. Manually tune system.
- d. Adjust R70 (pot 1K) for zero volts at test point.  
 NOTE: You must be able to change the test point voltage + or - with the pot.
- e. Change the RF power 0 to full, test point voltage has to stay around zero. (should not deviate more than ±.5 volt)
- f. Turn off the RF.
- g. Remove clip lead.

**II SENSOR ADJUSTMENT**

- a. All steps in the ETCH mode first, then check other modes.
- b. See I-b
- c. See I-c
- d. See I-d
- e. Adjust capacitor C14 (on the sensor box) to cause test point voltage to cross zero volts. This will occur at TWO(2) different settings of the capacitor. (higher capacity, clockwise and lower capacity counterclockwise). If not, two sensor outputs have to be "swapped" (to DS1 and DS2). Adjust the capacitor to the setting in which the test point voltage will cross zero at higher capacity. (Turn the capacitor clockwise).
- f. Check if you picked up the right one: move the "TUNE" control both directions, while observing the test point voltage.

The voltage has to change one or other direction (depends on the "TUNE" control) but it has to cross zero ONCE only! Also must not enter ±.25V region more than ONCE. If you get TWO(2) zero crossings, go back to I-e. Then repeat I-f. NOTE: If you are not able to get one enter only into the deadband (±.25V region), check the sensor to sputterhead cable length. It has to be 6 ft 1 inch. Difference more than ± 1/2 inch in length will cause two enters into the deadband in etch mode. Correct the cable(replace) and repeat sensor adjustment.

**IN HOUSE ONLY:** g. Switch into the Auto Mode. If the Servo Motor drives the tune-capacitor out of tune, then reverse I and M on connector J8 (blue and violet wires).

**IN THE FIELD ONLY:** Switch into the Auto Mode. If the Servo Motor drives the tune-capacitor out of tune, then reverse TBI-11 and 12 on 3400 and TBI-16 and 17 on 2400.

**WARNING:** HIGH VOLTAGE R.F. IS PRESENT DURING THESE ADJUSTMENTS. EXTREME CAUTION IS TO BE EXERCISED.

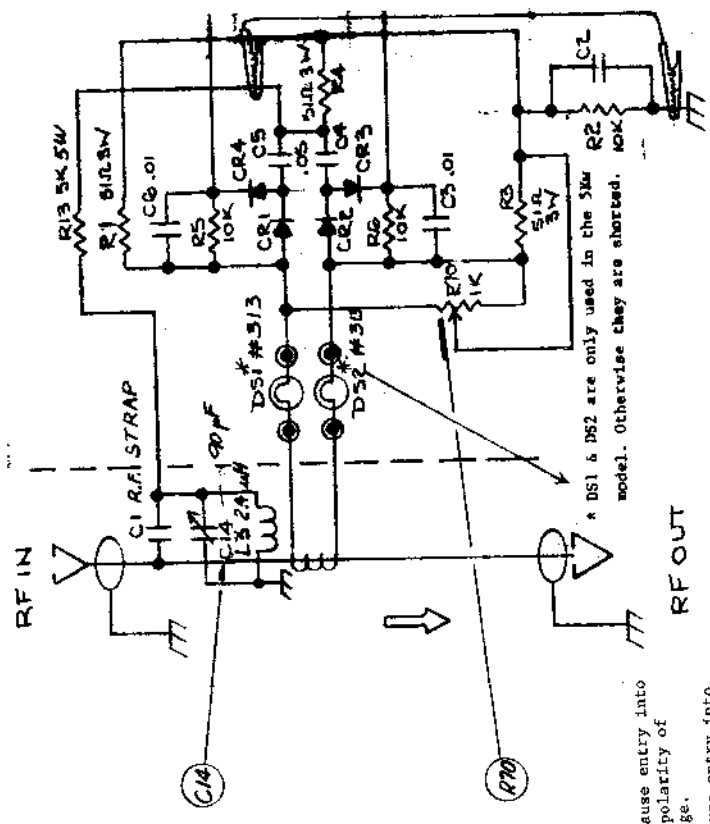

\* DS1 & DS2 are only used in the 3W model. Otherwise they are shorted.

Shorter cable will cause entry into .25 V region from polarity of the test point voltage.

Longer cable will cause entry into .25 V region from polarity of the test point voltage

**SERVO MATCH ADJUSTMENT PROCEDURE (B-221-166-50)**



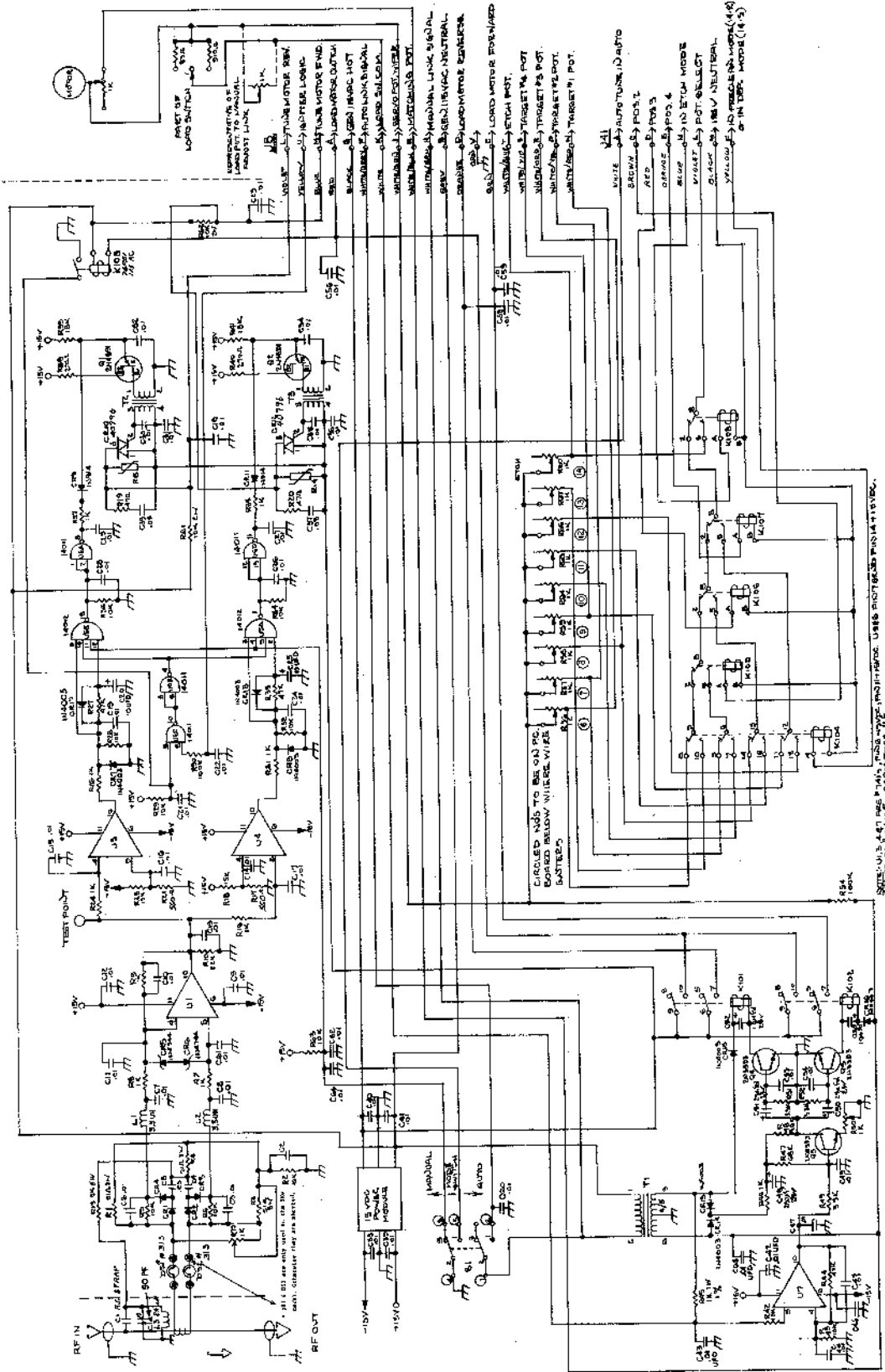

SERVO MATCH SCHEMATIC 3400-14 (D-221-119-300)

